

MAB 525

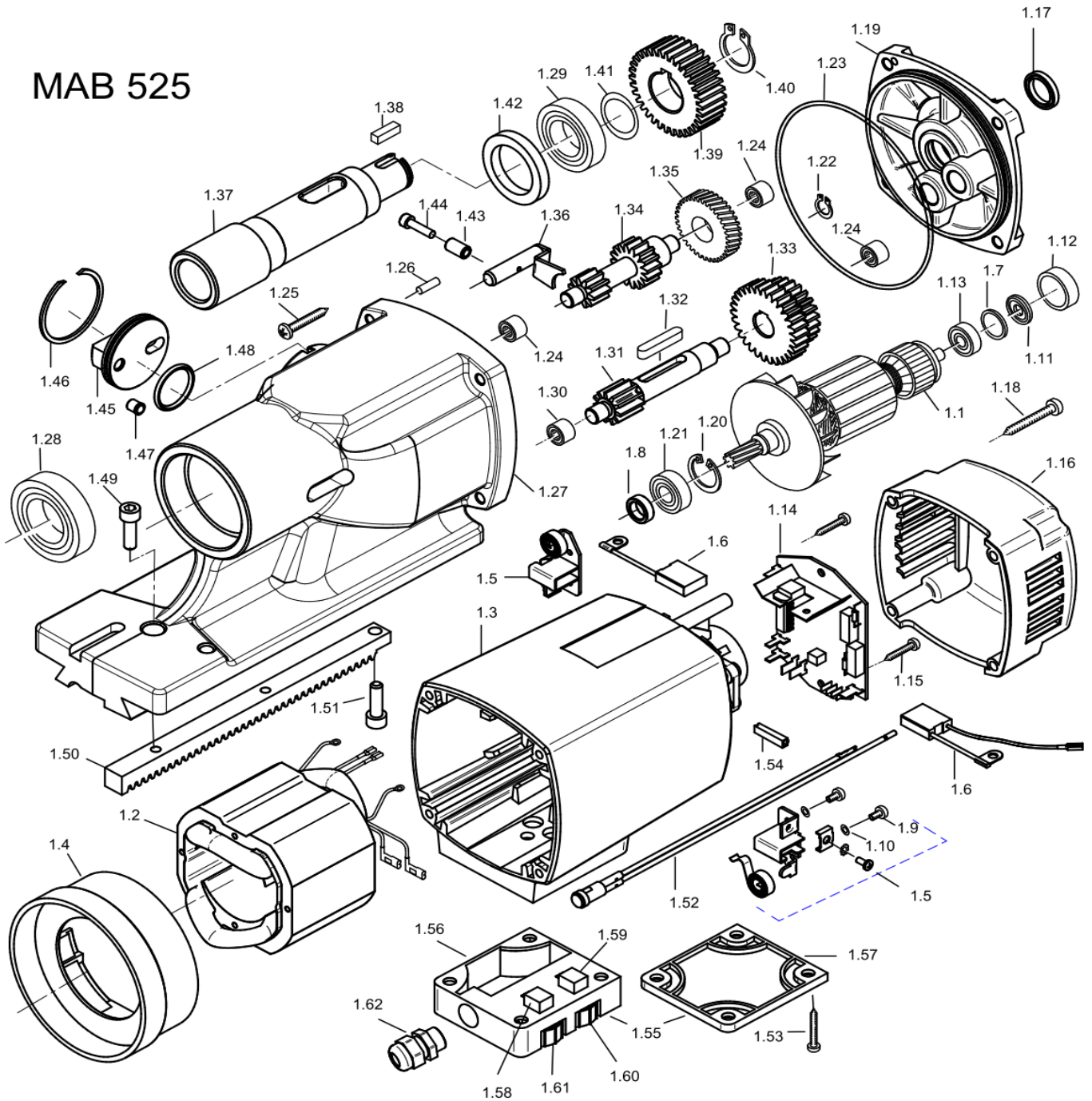

Pos. No.	Article no.	Description	pc
1.1.1	5012201	Armature 110 V	1
1.1.2	5012193	Armature 230V	1
1.2.1	5012551	Field coil 110 V	1
1.2.2	5011611	Field coil 230V	1
1.3.1	5012561	Motor housing until February 2012	1
1.3.2	5012562	Motor housing since February 2012	1
1.4	5012241	Air conducting ring	1
1.5	5011601	Carbon brush holder complete	2
1.6.1.1	5012541	Carbon brush 6,3x16x20 L41F13 110V until February 2012	2
1.6.2.1	5012542	Set of carbon brushes 6,3x16x20 L41F13 110V since February 2012	1
1.6.1.2	5012531	Carbon brush 6,3x16x20 L85F10 230V until February 2012	2
1.6.2.2	5012532	Set of carbon brushes 6,3x16x20 L85F10 230V since February 2012	1
1.7	5011741	Pressboard washer	1
1.8	5013411	Sealing sleeve	1
1.9	5013991	Self tapping screw ZM4x12	4
1.10	5013981	Corrugated spring washer B4 DIN 137	4
1.11	5011571	Ring magnet	1
1.12	5011561	Bearing cap	1
1.13	5011301	Ball bearing 6000 2Z	1
1.14.1	5014771	Motorplatine 110V	1
1.14.2	5011541	Motor board 230 V	1
1.15	5010951	Screw HC 3,9x9,5 DIN 7981	2
1.16	5011531	Cap for motor housing	1
1.17	5013601	Shaft seal KEIV 15x21x3	1
1.18	5010581	Screw HC 4,8x45 DIN 7981	4
1.19	5012572	Gearbox bearing plate	1
1.20	5010271	Circlip ring 28/1,2 DIN 472	1
1.21	5012501	Ball bearing 6001 2RS	1
1.22	5010261	Circlip ring 10/1 DIN 471	1
1.23	5012262	Gearbox seal O-Ring 94x2	1
1.24	5010351	Needle bearing HK 0810 DIN 625	3
1.25	5010911	Screw HC 5,5x38 DIN 7981	4
1.26	5010291	Pin M4x12 DIN 1474	1
1.27	5013901	Gearbox housing	1
1.28	5012331	Ball bearing 6006 2RS	1
1.29	5012281	Ball bearing 6004 2RS	1
1.30	5014591	Needle Bearing DL 0810	1
1.31	5012401	Shaft for gear wheel assembly	1
1.32	5010501	Spring A5x5x28	1
1.33	5012391	Gear wheel assembly	1
1.34	5012381	Shaft for gear wheels for 2 pinions	1
1.35	5012271	Intermedium gear wheel	1
1.36	5012352	Clutch complete	1
1.37	5012361	Spindle with groove	1
1.38	5012301	Spring A6x6x11	1
1.39	5012371	Spindle wheel	1
1.40	5012291	Circlip ring 20/1,2	1
1.41	5012321	Washer 20x28x0,1	1
1.42	5014521	Shaft seal WAS 28x37x6	1
1.43	5014581	Sleeve	1
1.44	5014531	Hexagon socket with pilot recess M4 x16 DIN 6912	1
1.45	5014541	Gear change	1
1.46	5014551	Circlip ring SB42	1

Pos. No.	Article no.	Description	pc
1.47	5014561	Pressure piece	1
1.48	5014601	O-Ring 36x1,5	1
1.49	6010011	Cylinder head bolt M6x16 DIN 912	1
1.50	6013511	Tooth rack	1
1.51	6010091	Cylinder head bolt M6x20 DIN 912	1
1.52	5015011	Control light for carbon brush	1
1.53	5013891	Screw HC 5,5x32 DIN 7981	4
1.54	5014741	Isolating grommet	1
1.55	5011981	Housing for potentiometer complete	1
1.56	5011661	Bottom part of housing for potentiometer without potentiometer and speed control	1
1.57	5011671	Cover for housing of potentiometer	1
1.58.1	5011461	Potentiometer for power control 220 Ohm	1
1.58.2	5011681	Potentiometer for power control 1 kOhm 7V	1
1.59	5011401	Potentiometer for speed control 100 kOhm 2V	1
1.60	5010861	Adjustment wheel blue for speed control 2V	1
1.61	5011701	Adjustment wheel red for power control 7V	1
1.62	7010021	Gland PG 9	1

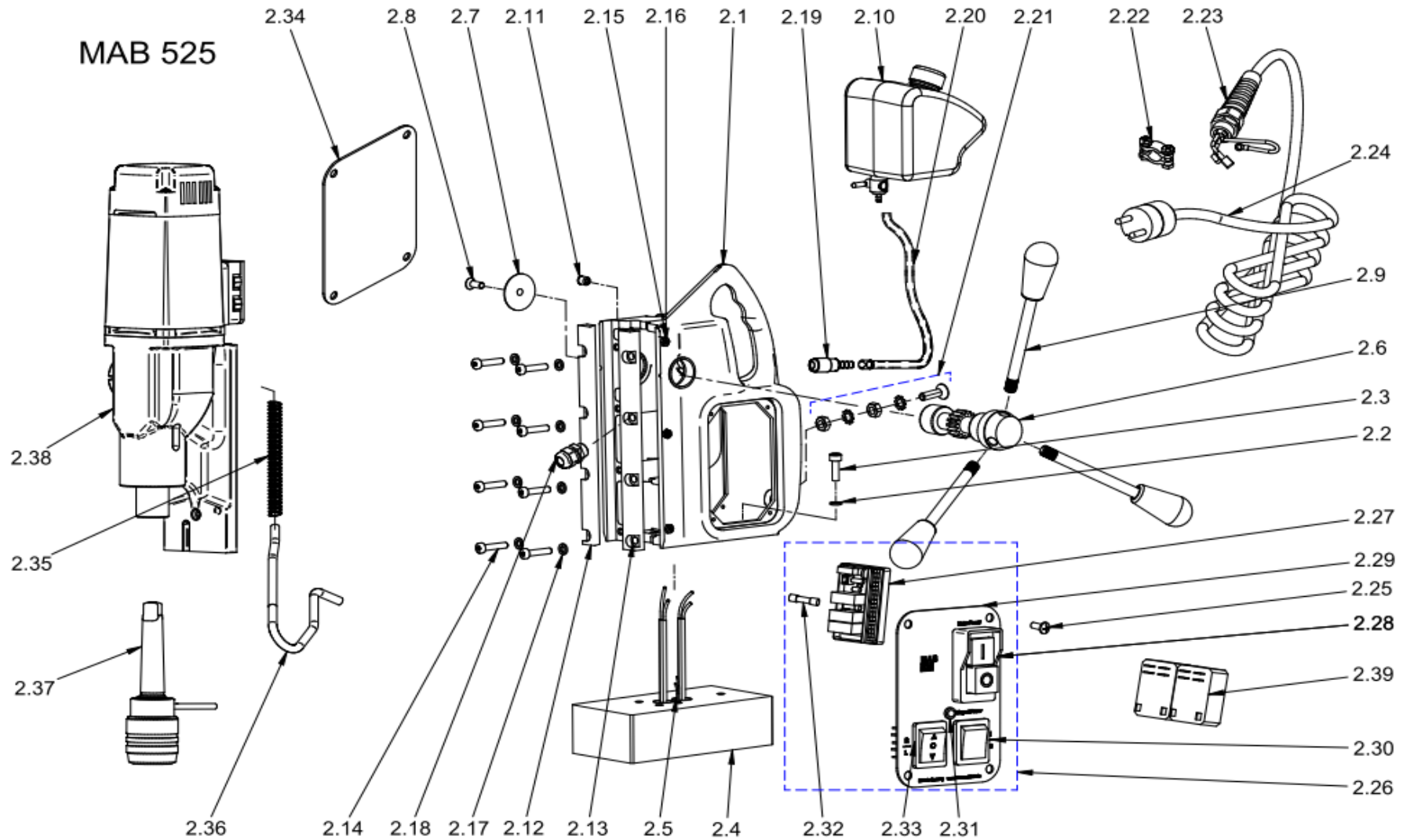

Pos. No.	Article no.	Description	pc
2.1	6012093	Housing for screwed guide rails (both sides)	1
2.2	6010021	Spring washer 6,1 DIN 7980	3
2.3	6010091	Cylinder head bolt M6x20 DIN 912	3
2.4	6013501	Magnet (electric) with indicator	1
2.5	6012171	Indicator with cable	1
2.6	6010211	Shaft for gear wheel	1
2.7	6010221	Washer for gear wheel 10,5x35x1,5	1
2.8	6010231	Screw M6x16 ISO 7047	1
2.9	6010242	Handle rod with knob	3
2.10	6012111	Coolant reservoir with tap	1
2.11	4000121	Pressure piece	1
2.12	6012251	Adjustment rail left, screwed, 4 holes	1
2.13	6012261	Adjustment rail right, screwed, 4 holes	1
2.14	6050141	Cylinder head bolt M6x25 DIN 7984	8
2.15	6010031	Nut M5 DIN 934	3
2.16	6010041	Adjusting screw M5x16 DIN 913	3
2.17	6050151	Washer 6,4x11x1,6 DIN 433	8
2.18	6012131	Cable gland PG9	1
2.19	ZSS 200K	Quick change coupling	1
2.20	ZSS 200S	Coolant tube blue, short 260mm	1
2.21	7010061	Earthing complete	1
2.22	4010291	Cord grip for connection cable	1
2.23	7010031	Mains cable gland PG 11	1
2.24.1.1	7010052	Connection cable 110 V with GB-plug	1
2.24.2.1	7010242	Connection cable 110V with US-plug	1
2.24.1.2	7010042	Connection cable 230V complete with plug	1
2.25	7010081	Screw M4x8 DIN 966	8
2.26.1	7011701	Switch plate compl. with PC board 1 relais and 2 additional relais 110V	1
2.26.2	7011691	Switch plate compl. with PC board 3 relais 230V	1
2.27.1	7011951	Switch plate compl. With PC board 1 relais 110V	1
2.27.2	6012152	Control board with 3 relais 230 V	1
2.28.1	7010931	Actuator 110 V	1
2.28.2	7010801	Actuator 230V	1
2.29	7010863	Switch plate front side for indicator	1
2.30	7010142	Magnet switch, 4 connection terminals	1
2.31	7010101	LED display for indicator red/green incl. cable and frame	1
2.32	7010131	Fuse 2A, 5x20	1
2.33	7010482	Rocker switch right/left	1
2.34	7011831	Cover of housing, back side	1
2.35	6012181	Spring for motor cable	1
2.36	6014171	Motor cable 670 mm	1
2.37	ZSS 200	Quick change drill chuck system Keyless MT 2	1
2.38.1.1	5015251	Motor complete 110V until February 2012	1
2.38.2.1	5015252	Motor complete 110V since February 2012	1
2.38.1.2	5005251	Motor complete 230V until February 2012	1
2.38.2.2	5005252	Motor complete 230V since February 2012	1
2.39	7011851	Relais 30A for control board 110V	2